

## GEL RECHARGEABLE BATTERY FOR HIGH RATE USE



### General Features

- Silica gel technology for longer cycle life and better performance at cold ambient temperatures.
- Special sheet separator and colloidal or foamed silica.
- Deep discharge cycle increased by 50% as compared with the AGM battery.
- High reliability and quality.
- Excellent recovery from deep discharge.
- Living up prevailing standards.

### Specification

Nominal Voltage	6V
Number of cell	3
Design Life	10 Years
Nominal Capacity 77°F(25°C)	
20 hour rate (21A, 5.25V)	210Ah
10 hour rate (18A, 5.25V)	180Ah
5 hour rate (31.06A, 5.25V)	155.3Ah
1 hour rate (121.6A, 4.8V)	121.6Ah
Internal Resistance	
Fully Charged battery 77°F(25°C)	16mOhms
Self-Discharge	
3% of capacity declined per month at 20°C(average)	
Operating Temperature Range	
Discharge	-20~60°C
Charge	-10~60°C
Storage	-20~60°C
Max. Discharge Current 77°F(25°C)	2000A(5s)
Short Circuit Current	4500A
Charge Methods: Constant Voltage Charge 77°F(25°C)	
Cycle use	7.25-7.45V
Maximum charging current	60A
Temperature compensation	-15mV/°C
Standby use	6.8-6.9V
Temperature compensation	-10mV/°C

### Dimensions and Weight

Length(mm / inch)	243/9.55
Width(mm / inch)	188/7.39
Height(mm / inch)	275/10.8
Total Height(mm / inch)	299/11.7
Approx. Weight(Kg / lbs)	33/72.7
Standard Terminal	I

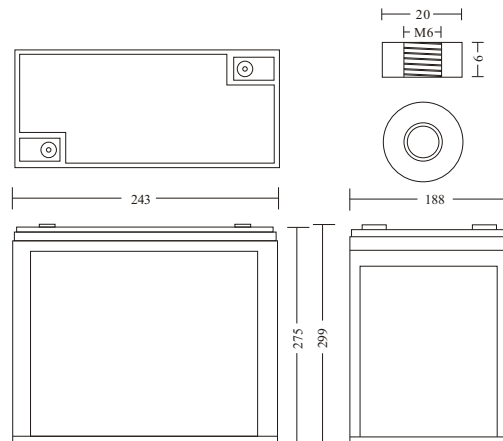

### Discharge Constant Power (Watts at 77°F25°C)

End Point Volts/Cell	5min	10min	15min	30min	1h	3h	5h	10h	2h
1.60V	1224	895	658	395	231	93.6	61.2	37.7	64.8
1.65V	1199	855	645	389	230	93.5	60.8	37.4	63.6
1.70V	1132	826	637	385	228	92.8	60.6	37.1	62.4
1.75V	1019	763	606	376	226	92.3	60.1	36.7	61.2
1.80V	917	693	557	359	220	90.1	59.2	36.4	59.7

### Discharge Constant Current (Amperes at 77°F25°C)

End Point Volts/Cell	5min	10min	15min	30min	1h	3h	5h	10h	20h
1.60V	684	490	357	210	121	48.8	31.7	18.6	20.2
1.65V	666	466	349	206	120	48.6	31.6	18.5	20.1
1.70V	628	450	344	205	119	48.2	31.4	18.3	20.1
1.75V	564	416	328	200	118	48.0	31.1	18.0	20.0
1.80V	509	378	301	190	116	46.8	30.5	17.9	20.0

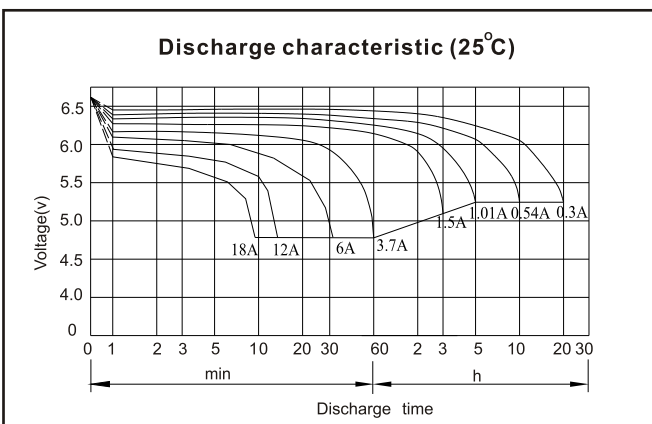
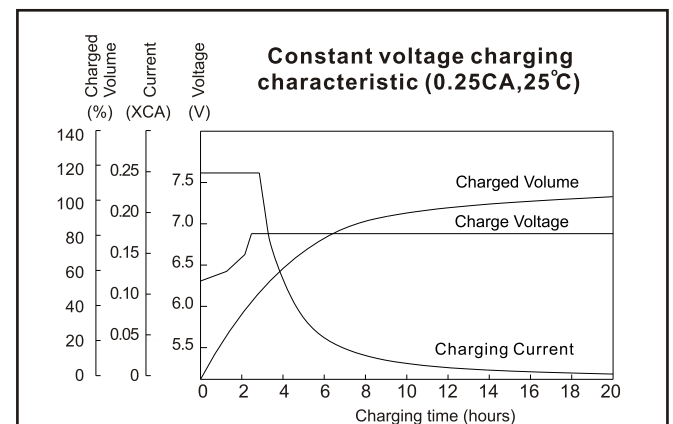

### GEL RECHARGEABLE BATTERY FOR HIGH RATE USE

